

EDFA Gain Performance analysis at 2Gbits/sec in Optical Transmission System

Warsha Balani^{a*} and Manish Saxena^b

^aDepartment of Electronics and Communication Engineering, M.Tech Student, BIST Bhopal, M.P, India.

^bDepartment of Electronics and Communication Engineering: Assistant Prof., BIST Bhopal, M.P, India.

Accepted 02 July 2013, Available online 01 August 2013, (July/Aug 2013 issue)

Abstract

We investigate the gain-flattening characteristics of erbium-doped fiber amplifier (EDFA) in C-band (1525-1565 nm) by employing the 1480 nm as well as 980 nm pumping configuration. We achieved the flat amplification in erbium-doped fiber (EDF) using Non-uniform FBG (fiber Bragg Grating). One major problem of EDFA which is amplified spontaneous emission (ASE) generated by stimulation emission during amplification of input signals[1]. The ASE is a background noise. This noise signal were being amplified with the input signal when pass through another amplifier. The output signal power increases will the decreases in the spacing between gratings in FBG. The output signal power can be optimized by maximizing the gain. Moreover, the gain is the parameter of the doping concentration and doping profile of the erbium doped fiber, length of the fiber, windows wavelength of input signal, input powers and the pump power. The increase the input signal power certainly will increase the output signal power but the gain decreases [4]. We also used the simulation tools optisim to investigate the characteristics of C-band EDFA with the same configuration.

Keywords: EDFA, FBG, Gain Flattening, ASE, WDM, Optisystem software, Transmission Bands

1. Introduction

Optical Amplifier can lessen the effects of dispersion and attenuation allowing improved performance of long-haul optical systems.

In optical fiber network, amplifiers are used to regenerate an optical signal ,amplify and then retransmitting an optical signal. In long-haul optical systems, many amplifiers are needed to prevent the output of signal seriously attenuated. In order to reduce the cost, the amount of amplifiers can be reduced by increase the spacing between them. Current spacing of Erbium Doped Fiber Amplifier (EDFA) is in the range of 80km to 100km.

The gain spectrum of EDFA is not inherently flat. For single channel systems, the gain variation is not a problem. However, in optical fiber network, as the number of channel increases, the transmission problem arises. The gain flatness is importance for EDFA's wavelength division multiplexing (WDM) which is important technique for long haul optical transmission link system. They typically present gain peaking at about 1530 nm and the useful gain bandwidth may be reduced to less than 10 nm. There are one major problem of EDFA which is amplified spontaneous emission (ASE) generated by stimulation emission during amplification of input signals. The ASE is a background noise. This noise signal were being amplified with the input signal when

pass through another amplifier. The output signal power increases will the decreases in the spacing of the EDFA. The output signal power can be optimized by maximizing the gain. Moreover, the gain is the parameter of the doping concentration and doping profile of the erbium doped fiber length of the fiber, windows wavelength of input signal, input powers and the pump power. But the length of the fiber is the spacing of repeater where is one of the project outcome of this project. OPTISYSTEM is a design and simulation software for fiber optics application. OPTISYSTEM enables users to design and simulate next generation optical networks, current optical networks, SONET/SDH ring networks, amplifiers, receivers, transmitters .This software has many analysis such as tools eye diagrams, BER, Q-Factor, Signal chirp, polarization state, constellation diagrams, signal power, gain, Noise Figure, OSNR, data monitors, report generation, and etc.

2. WDM: Wavelength Division Multiplexing

Optical fibers can carry multiple light signals of different wavelength simultaneously. The technique which allows the optical fiber to carry multiple signals is called wavelength division multiplexing .So wavelength division multiplexing is the technique of sending signals of several different wavelengths of Light into the fiber simultaneously. In fiber optic communications,

wavelength division Multiplexing (WDM) is a technology which multiplexes multiple optical carrier signals on a single optical fiber by using different wavelengths of Laser light to carry different signals. This helps to increase capacity and also helps bi-directional transmission over a single fiber length for transmitter and receiver

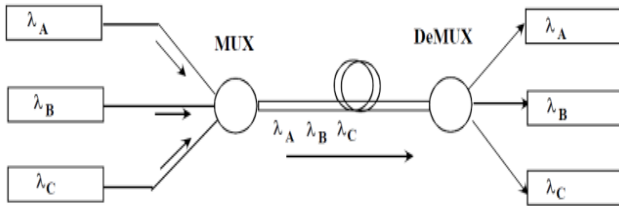

Figure 1: Wavelength division multiplexing

3. Optical Amplifiers

When a signal travels in an optical fiber it suffers from various losses like fiber attenuation losses, fiber tap losses and fiber splice losses. Due to these losses it is difficult to detect the signal at the receiver side. So in order to transmit signal over a long distance in a fiber (more than 100km) it is necessary to compensate the

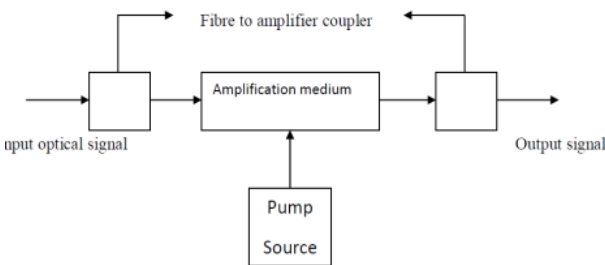

Figure 2: Block Diagram of optical amplifier

Raman Amplifier have broadest band among the optical amplifiers wherefrom O band to U band. Whereas, EDFA is mostly work on C band or L band

Table 1: Transmission window bands

Band	Description	Wavelength Range
O band	original	1260 to 1360 nm
E band	extended	1360 to 1460 nm
S band	short wavelengths	1460 to 1530 nm
C band	conventional ("erbium window")	1530 to 1565 nm
L band	long wavelengths	1565 to 1625 nm
U band	Ultra-Long wavelengths	1625 to 1675 nm

losses in the fiber. Initially the optical signals were converted to electrical signal then amplified and then

reconverted to optical signal. But it was a complex and costly procedure. The introduction of optical amplifiers allowed the signal amplification in optical domain. There are mainly two types of optical amplifiers: semiconductor optical amplifier and fiber amplifiers. Optical amplifiers were again divided into travelling wave semiconductor optical amplifier and Fabry-perot semiconductor optical amplifier. Fiber amplifiers are divided into Erbium doped fiber amplifier, Raman amplifier and Brillion amplifier.

4. Erbium Doped Fiber Amplifier (EDFA)

Erbium doped fiber is a conventional silica fiber heavily doped with active erbium ions as the gain medium. Erbium ions (Er³⁺) are having the optical fluorescent properties that are suitable for the optical amplification. There are practically two wavelength widows C-Band (1530nm-1560nm) and L-Band (1560nm-1600nm). EDFA can amplify a wide wavelength range (1500nm-1600nm) simultaneously, hence is very useful in wavelength division multiplexing for amplification. EDFA basic says when an optical signal such as 1550nm wavelength signal enters the EDFA from input, the signal is combined with a 980nm or 1480nm pump laser through a wavelength division multiplexer device. The input signal and pump laser signal pass through fiber doped with erbium ions. Here the 1550nm signal is amplified through interaction with doped erbium ions [4].

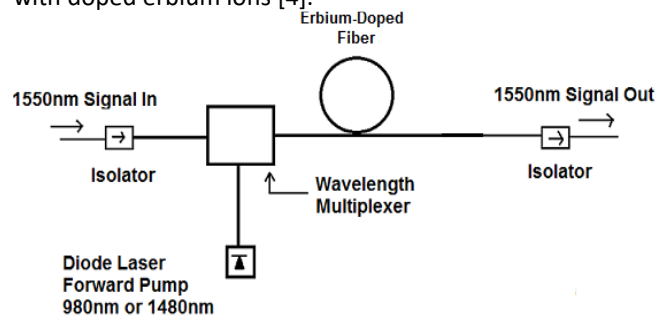

Figure 3: Erbium doped fiber amplifier Design

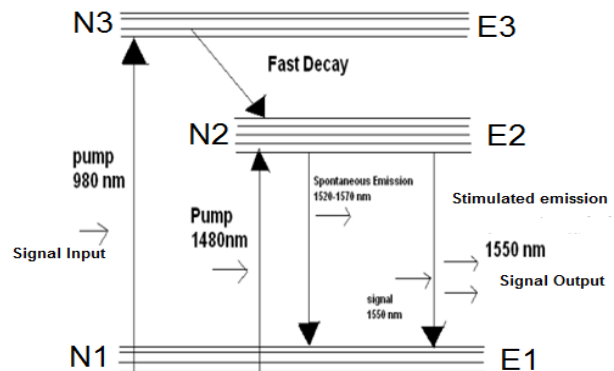

Figure 4: Three level energy diagram of Er³⁺ ions

The three energy levels E1, E2, E3 are the ground, meta-stable and excited state levels respectively. The

population of erbium ions in the three levels are denoted by N_1, N_2, N_3 respectively. The population density is $N_1 > N_2 > N_3$ in equilibrium state, when no pump signal is used. When pump or signal is present the population density of levels changes with the movement of ions between the levels, through the emission or absorption of photons at frequencies determined by the energy-level difference.

As shown in the figure 4 two pump wavelengths can be used for EDFA i.e. 980nm and 1480nm. With 980nm pumping wavelength the Er^{3+} ions in the ground state (E1) are excited to the excited state (E3). The rate of transition from ground state to the excited state depends upon the pump power. The ions in the excited state are not going to stay there for a long time and decays back to the meta-stable state and then fall back to the ground state after approximately 10ms and emits photon. This is called spontaneous emission. But photons generated in this spontaneous process are treated as noise as the photons are non-polarized and incoherent through time and space. But when the ions or photons that are in the metastable state incident with light photons of suitable wavelength, they fall back to the ground state emitting photons having same phase, frequency and polarization and travel in the same direction as the photons of the incident wave. This is called stimulated emission. In this process one photon gives two photons at the output. Hence multiplication of photons occurs and multiple number of photons subjected at the input generates large number of photons at the output which increases the light intensity which we call gain and it amplifies the input signal. With 1480nm the ions in the ground state excited directly to the meta-stable state and the above process occurs. When the number of ions in the excited state or meta-stable state is greater than the ions in the ground state then the population inversion mechanism occurs

5. Fiber Bragg grating

Fiber Bragg grating may be a sort of distributed Bragg reflector made in a very short section of glass fiber that reflects explicit wavelengths of and transmits all others. This is achieved by making a periodic variation in the refractive index of the fiber core, which generates a wavelength specific dielectric mirror [5]. A fiber Bragg grating will thus be used as an inline optical filter to block certain wavelengths, or as a wavelength-specific reflector

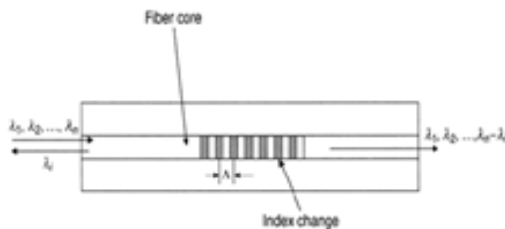

Figure 5: Fiber Bragg grating

The refractive index of the fiber core vary sporadically on the length of the fiber

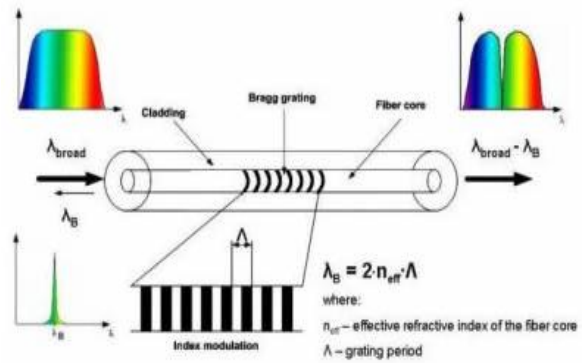

Figure 6: Bragg grating equation

Where n_{eff} is the effective refractive index of the fiber core, and λ_B is the wavelength of the light reflected by the Bragg grating. Therefore, the Bragg grating wavelength λ_B can be expressed as $\lambda_B = 2n_{eff}\Lambda$. When a light with a broad spectrum is launched into one end of fiber containing a fiber Bragg grating, the part of the light with wavelength matching the Bragg grating wavelength will be reflected back to the input end, with the rest of the light passing through to the other end. The fundamental principle behind the operation of fiber Bragg grating (FBG) is Fresnel reflection [2]. Under the Bragg condition, the reflected light is exactly in phase with reflected lights from other grating planes. FBG acts as a Band-pass filter at the reflection port and a Band-rejection filter at the transmission port.

6. FBG Application

6.1. Optical Add-Drop Multiplexer (OADM)

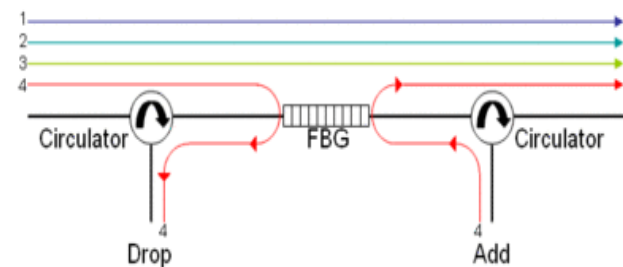

Figure 7: Optical add/drop multiplexer

The primary application of fiber Bragg gratings is in optical communications systems. They are specifically used as notch filters. They are also used in optical multiplexers and demultiplexers with an optical circulator, or optical add-drop multiplexer (OADM). Figure shows 4 channels, depicted as 4 colors, impinging onto a FBG via an optical circulator. The FBG is set to reflect one of the channels, here channel 4. The signal is reflected back to the circulator where it is directed down and dropped out of the system. Since the channel has been dropped, another signal on that channel can be added at the same point in the network. A demultiplexer can be achieved by cascading multiple drop sections of the

OADM, where each drop element uses an FBG set to the wavelength to be demultiplexed. Conversely, a multiplexer can be achieved by cascading multiple add sections of the OADM. FBG demultiplexers and OADMs can also be tunable. In a tunable demultiplexer or OADM, the Bragg wavelength of the FBG can be tuned by strain applied by a piezoelectric transducer

6.2. Chromatic Dispersion Compensation

Another use of fiber gratings is to compensate for chromatic dispersion in an optical fiber. The grating serves as a selective optical delay line, which adjusts the transit times of different wavelengths in a pulse so they are approximately equal.

FBG have been proposed for compensating the chromatic dispersion .Such a device reflects light when its wavelength corresponds to the grating period .When the grating is chirped, that is when its period varies linearly along the axis; the different spectral components of the light are reflected at different location along the grating .In such a way, a spectral component travelling faster in the transport fiber can be delayed by the FBG compared to a spectral component that travels slower.

Dispersion Compensation: Recompress the optical pulses using a chirped grating

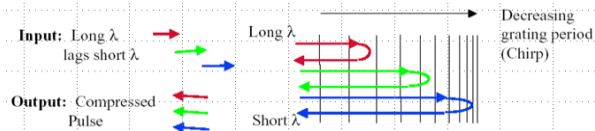

Figure 8: Dispersion Compensation

7. Simulation Model

The transmitter section consists of data source, Laser source and Mach-Zehnder modulator. The data source is then converted to Non-Return to Zero (NRZ) format. The Data source and laser signal are fed to the Mach-Zehnder modulator, where the inputs generated from data source are modulated with the laser signal are transmitted. The output from the modulator is now an optical signal with certain wavelength. When multiple optical signals are transmitted in a fiber they are multiplexed with wavelength division multiplexer. The multiplexed signal is then passed through the SMF fiber, then through the optical amplifier (EDFA) and then through the DCF fiber to the detector. In the detector section the de-multiplexer is used to get the different optical signals with different wavelengths which were multiplexed at the transmitter side. The Receiver side consists of photo-detector, low-pass filter and the BER analyzer. The photo-detector detects the optical signal and then the signal is passed through a low pass filter. The BER analyzer is used to check the Bit Error rate and the Q-factor of each signal

8. Simulation Result

First, the observation of the ASE spectrum, as shown in Fig 2, is performed at a maximum pump power of 150 mW for forward pump lasers and 100 mW for backward pump laser. As shown in the figure, the ASE spectrum is flatter for the EDFA configured with the broadband FBG in between the stages. The FBG functions to block the C-band ASE from travelling between the stages and thus enhances and flattens the overall gain of the wide-band EDFA. Since the C-band gain is very low in the second stage, the lasing due to the oscillation of the C-band ASE between the FBG and loop mirror does not occur. With the forward-pumping scheme, free-running lasing was observed at 1530 to 1540 nm due to the spurious

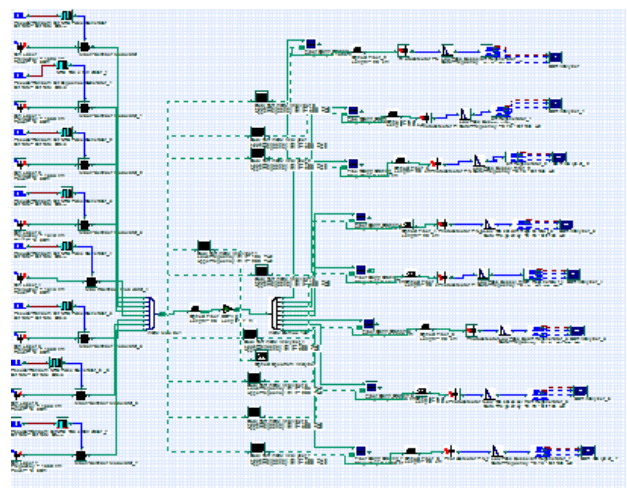

Figure 9: Simulation model

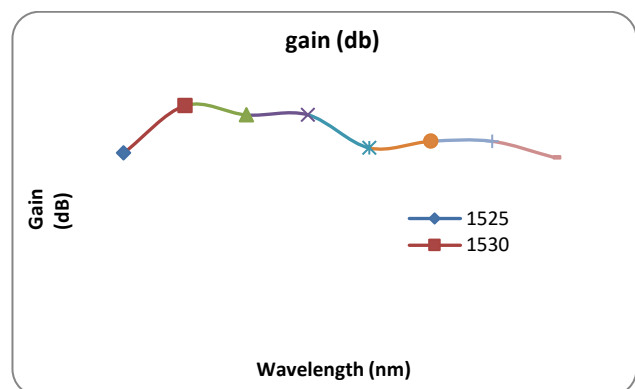

Figure 10: Flattened Gain of EDFA

reflection in the cavity. Spurious reflections might occur from linear or nonlinear scattering in the optical fiber or from reflections from the fiber splices. The free-running laser will suppress the ASE level beside it and affect the gain level in this region. After 1540 nm the gain is approximately in flat nature At the optimum pump power, the gain and noise figure were measured across C-band wavelength regions for input signal level; -25 dBm . Fig 1 shows the gain characteristic across the wavelength

region from 1525–1620 nm for an input signalpowerof-25db

9. Acknowledgement

This research project had been carried out in the Optical communication laboratory under the Dept. of Electronics and Communication, BIST Bhopal. All authors and co-authors are contributed in this project.

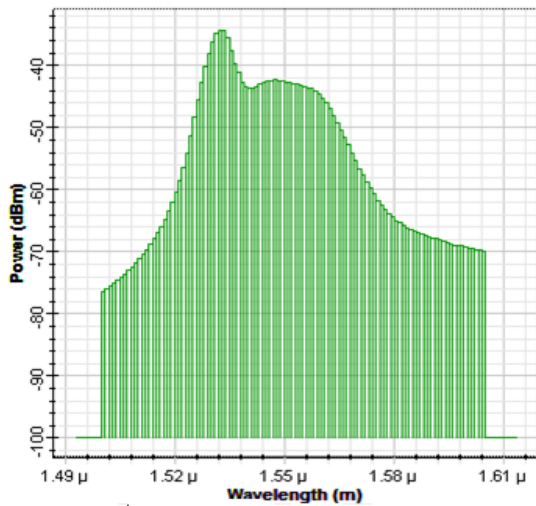

Figure 11: ASE of EDFA

References

- [1]. Liu Kaixian, Du Juan Research of EDFA Gain Flattening based on Chirped Fiber Bragg Grating 2009 [1].
- [2]. N. M. Litchinitser, B. J. Eggleton Interaction of Bragg solitons in fiber gratings 1999 [2]
- [3]. JungMi Oh, Sang Geun Koo, Donghan Lee 2008 [3] entitled as Enhancement of the Performance of a Reflective SOA-Based Hybrid WDM/TDM PON System with a Remotely Pumped Erbium-Doped Fiber Amplifier
- [4]. X. S. Cheng, R. Parvizi, H. Ahmad [4] entitled as Wide-Band Bismuth-Based Erbium-Doped Fiber Amplifier with a Flat-Gain Characteristic Volume 1 2009.
- [5]. K. O. Hill G. Meltz Fiber Bragg grating technology fundamentals and overview 1997 [5]